

SERIES LC - CLAMP, LOOP CUSHIONED

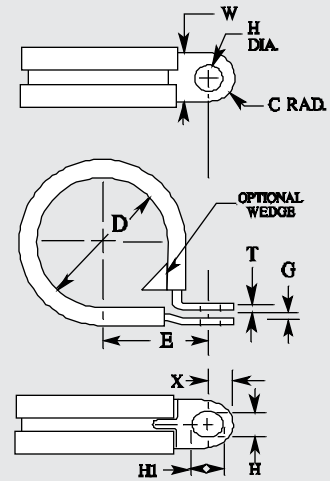

J&M PART NUMBER	D +/- .015	E +/- .015	W	H	H1	T	G	X	C
								RAD	
* 43LC1 43LC60	-2 .125 TO-16 TO1.000	D/2 + .322	.375	.204	.294	.030	.06	** .188	.38
	-17 1.062 TO-96 TO6.000	D/2 + .342							
* 44LC1 44LC60	-2 .125 TO-16 TO 1.000	D/2 + .402	.500	.204	.294	.030	.06	.218	.38
	-17 1.062 TO-96 TO 6.000	D/2 + .490							
* 54LC1 54LC6	-4 .250 TO -8 TO .5000	D/2 + .514	.63	.281	.371	.030	.06	.312	.50
	-9 .562 TO -16 TO 1.000	D/2 + .534							
	-17 1.062 TO-96 TO 6.000	D/2 + .534							
* 55LC1 55LC6	-4 .250 TO -8 TO .500	D/2 + .514	.63	.281	.371	.030	.06	.312	.50
	-9 .562 TO -16 TO 1.000	D/2 + .534							
	-17 1.062 TO-96 TO 6.000	D/2 + .534							
* 56LC1 56LC6	-4 .250 TO -8 TO .500	D/2 + .514	.75	.281	.371	.030	.06	.312	.50
	-9 .562 TO-16 TO 1.000	D/2 + .534							
	-17 1.062 TO-96 TO 6.000	D/2 + .534							
* 65LC1 65LC6	-4 .250 TO -8 TO .5000	D/2 + .514	.63	.343	.433	.030	.06	.312	.50
	-9 .562 TO-16 TO 1.000	D/2 + .534							
	-17 1.062 TO-96 TO 6.000	D/2 + .534							
* 66LC1 66LC6	-4 .250 TO-8 TO .500	D/2 + .514	.75	.343	.433	.030	.06	.312	.50
	-9 .562 TO-16 TO 1.000	D/2 + .534							
	-17 1.062 TO-96 TO 6.000	D/2 + .534							

J&M PART NUMBER	D +/- .015	E +/- .015	W	H	H1	T	G	X	C
									RAD
* 75LC1 75LC6	-4 .250 TO-8 TO .500	D/2 + .514	.63	.406	.496	.030	.06	.312	.50
	-9 .562 TO-16 TO 1.000	D/2 + .534							
	-17 1.062 TO-96 TO 6.000	D/2 + .534							
* 76LC1 76LC6	-4 .250 TO -8 TO .500	D/2 + .514	.75	.406	.496	.030	.06	.312	.50
	-9 .562 TO-16 TO 1.000	D/2 + .534							
	-17 1.062 TO-96 TO 6.000	D/2 + .534							
* 86LC1 86LC6	-4 .250 TO-8 TO .500	D/2 + .562	.75	.468	.558	.030	.06	** .375	.81
	-9 .562 TO-16 TO 1.000	D/2 + .582							
	-17 1.062 TO-96 TO 6.000	D/2 + .582							
* 88LC1 88LC6	-4 .250 TO-8 TO .500	D/2 + .562	1.0	.468	.558	.040	.06	.437	.81
	-9 .562 TO-16 TO 1.000	D/2 + .582							
	-17 1.062 TO-96 TO 6.000	D/2 + .582							
* 96LC1 96LC6	-4 .250 TO-8 TO .500	D/2 + .623	.75	.531	.621	.030	.06	.375	.81
	-9 .562 TO-16 TO 1.000	D/2 + .643							
	-17 1.062 TO-96 TO 6.000	D/2 + .643							
* 98LC1 98LC6	-4 .250 TO -8 TO .500	D/2 + .623	1.0	.531	.621	.040	.06	.437	.81
	-9 .562 TO-16 TO 1.000	D/2 + .643							
	-17 1.062 TO-96 TO 6.000	D/2 + .643							

* Denotes Slotted Lower Foot ** 43LC1/86LC1 Only - See Appendix For Materials, Finishes and Ordering Information.

SERIES CC - CLAMP, CENTER MOUNT CUSHION

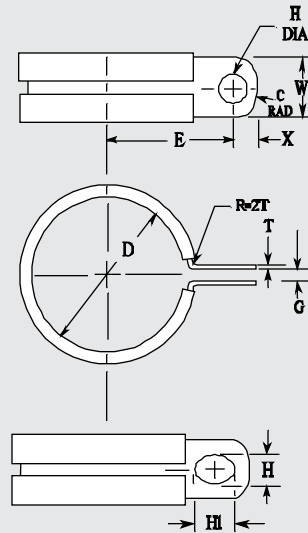

J&M PART NUMBER		D	E +/- .015	W +/- .015	H	H1	T	G	X	C RAD
* 43CC1	-2	.125	D/2	.375	.204	.294	.030	.06	**.188	.38
* 43CC6	TO -16	TO 1.000	+ .322							
	-17	TO 6.000	+ .342							
* 44CC1	-2	.125	D/2	.500			.030	.06	.218	
* 44CC6	TO -16	TO 1.000	+ .402							
	-17	TO 6.000	+ .490							
* 54CC1	-4	.250	D/2	.281	.371	.030	.06	.12	.312	.50
* 54CC6	TO -8	TO .500	+ .514							
	-9	TO 1.000	+ .534							
	-17	TO 6.000	+ .534			.050				
* 55CC1	-4	.250	D/2	.63			.030	.06	.12	
* 55CC6	TO -8	TO .500	+ .514							
	-9	TO 1.000	+ .534							
	-17	TO 6.000	+ .534			.050				
* 56CC1	-4	.250	D/2	.75			.030	.06	.12	
* 56CC6	TO -8	TO .500	+ .514							
	-9	TO 1.000	+ .534							
	-17	TO 6.000	+ .534			.050				
* 65CC1	-4	.250	D/2	.63	.343	.433	.030	.06	.12	
* 65CC6	TO -8	TO .500	+ .514							
	-9	TO 1.000	+ .534							
	-17	TO 6.000	+ .534			.050				
* 66CC1	-4	.250	D/2	.75			.030	.06	.312	.50
* 66CC6	TO -8	TO .500	+ .514							
	-9	TO 1.000	+ .534							
	-17	TO 6.000	+ .534			.050				

J&M PART NUMBER		D	E +/- .015	W +/- .015	H	H1	T	G	X	C RAD
* 75CC1	-4	.250	D/2	.63	.406	.496	.030	.06	.312	.50
* 75CC6	TO -8	TO .500	+ .514							
	-9	TO 1.000	+ .534							
	-17	TO 6.000	+ .534			.050				
* 76CC1	-4	.250	D/2	.75			.030	.06		
* 76CC6	TO -8	TO .500	+ .514							
	-9	TO 1.000	+ .534							
	-17	TO 6.000	+ .534			.050				
* 86CC1	-4	.250	D/2	.75			.030	.06	**.375	
* 86CC6	TO -8	TO .500	+ .562							
	-9	TO 1.000	+ .562							
	-17	TO 6.000	+ .582			.050				
* 88CC1	-4	.250	D/2	1.0			.040	.06	.437	.81
* 88CC6	TO -8	TO .500	+ .562							
	-9	TO 1.000	+ .562							
	-17	TO 6.000	+ .582			.050				
* 96CC1	-4	.250	D/2	.75	.531	.621	.030	.06	.375	
* 96CC6	TO -8	TO .500	+ .623							
	-9	TO 1.000	+ .643							
	-17	TO 6.000	+ .643			.050				
* 98CC1	-4	.250	D/2	1.0			.040	.06	.437	
* 98CC6	TO -8	TO .500	+ .623							
	-9	TO 1.000	+ .623							
	-17	TO 6.000	+ .643			.050				

* Denotes Slotted Lower Foot ** 43CC1/86CC1 Only - See Appendix For Materials, Finishes and Ordering Information.

SERIES MC - CLAMP, MULTI-LOOP CUSHION

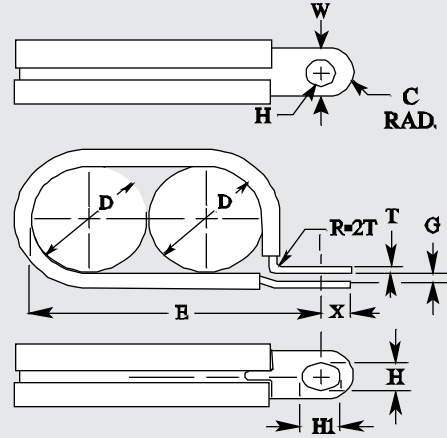

J&M PART NUMBER	D +/- .015	E +/- .015	W	H	H1	T	G	X	C RAD
* 43 MC1	-2 TO	DIA.X# OF	.375	.204	.294	.030	.06	**.188	.38
43 MC6	-16 TO	TUBE+.322							
	-17 TO	DIA.X# OF							
	-96	6.000 TUBE+.342				.050	.12		
* 44 MC1	-2 TO	DIA.X# OF	.500			.030	.06	.218	
44 MC6	TO-16	1.000 TUBE+.402							
	-17 TO	DIA.X# OF							
	TO-96	1.062 TO 6.000 TUBE+.490				.050	.12		
* 54 MC1	-4 TO	.250 TO DIA.X# OF	.500			.030	.06	.312	.50
54 MC6	TO -8	.500 DIA.X# OF							
	-9 TO-16	.562 TO 1.000 TUBE+.514							
	-17 TO-96	1.062 TO 6.000 TUBE+.534							
* 55 MC1	-4 TO	.250 TO DIA.X# OF	.630	.281	.371	.030	.06	.12	.81
55 MC6	TO -8	.500 DIA.X# OF							
	-9 TO-16	.562 TO 1.000 TUBE+.514							
	-17 TO-96	1.062 TO 6.000 TUBE+.534							
* 56 MC1	-4 TO	.250 TO DIA.X# OF	.750			.030	.06	.12	.312
56 MC6	TO -8	.500 DIA.X# OF							
	-9 TO-16	.562 TO 1.000 TUBE+.514							
	-17 TO-96	1.062 TO 6.000 TUBE+.534							
* 65 MC1	-4 TO	.250 TO DIA.X# OF	.630	.343	.433	.030	.06	.12	.50
65 MC6	TO -8	.500 DIA.X# OF							
	-9 TO-16	.562 TO 1.000 TUBE+.514							
	-17 TO-96	1.062 TO 6.000 TUBE+.534							
* 66 MC1	-4 TO	.250 TO DIA.X# OF	.750			.030	.06	.12	
66 MC6	TO -8	.500 DIA.X# OF							
	-9 TO-16	1.000 TUBE+.514							
	-17 TO-96	1.062 TO 6.000 TUBE+.534							

J&M PART NUMBER	D +/- .015	E +/- .015	W	H	H1	T	G	X	C RAD
* 75 MC1	-4 TO	.250 TO DIA.X# OF	.63	406	.496	.030	.06	.312	.50
75 MC6	TO -8	.500 DIA.X# OF							
	-9 TO-16	.562 TO 1.000 TUBE+.514							
	-17 TO-96	1.062 TO 6.000 TUBE+.534							
* 76 MC1	-4 TO	.250 TO DIA.X# OF	.75			.030	.06	.12	
76 MC6	TO -8	.500 DIA.X# OF							
	-9 TO-16	.562 TO 1.000 TUBE+.514							
	-17 TO-96	1.062 TO 6.000 TUBE+.534							
* 86 MC1	-4 TO	.250 TO DIA.X# OF	468	.558		.030	.06	.12	.375
86 MC6	TO -8	.500 DIA.X# OF							
	-9 TO-16	.562 TO 1.000 TUBE+.562							
	-17 TO-96	1.062 TO 6.000 TUBE+.582							
* 88 MC1	-4 TO	.250 TO DIA.X# OF	1.0			.040	.06	.12	.437
88 MC6	TO -8	.500 DIA.X# OF							
	-9 TO-16	.562 TO 1.000 TUBE+.562							
	-17 TO-96	1.062 TO 6.000 TUBE+.582							
* 96 MC1	-4 TO	.250 TO DIA.X# OF	.75	531	.621	.030	.06	.12	.375
96 MC6	TO -8	.500 DIA.X# OF							
	-9 TO-16	.562 TO 1.000 TUBE+.562							
	-17 TO-96	1.062 TO 6.000 TUBE+.582							
* 98 MC1	-4 TO	.250 TO DIA.X# OF	1.0			.040	.06	.12	.437
98 MC6	TO -8	.500 DIA.X# OF							
	-9 TO-16	.562 TO 1.000 TUBE+.562							
	-17 TO-96	1.062 TO 6.000 TUBE+.582							

* Denotes Slotted Lower Foot ** 43MC1/86MC1 Only - See Appendix For Materials, Finishes and Ordering Information.

SERIES RC - CLAMP, RECTANGULAR LOOP, CUSHION

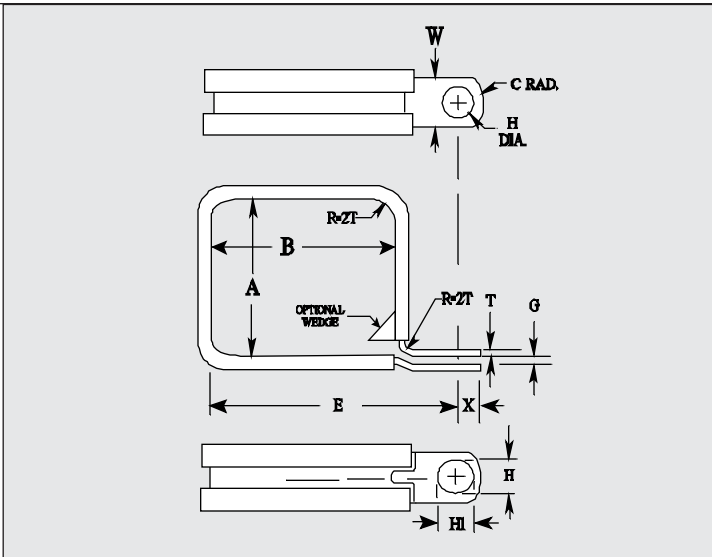

J & M PART NO.	A DIM MIN .250	B DIM MIN .375	E +/- .015	W	H	HI	T	G	X	C RAD
* 43RC1			B+ .322	.375			.030	.06	** .188	
* 43RC60	REC	REC	B+ .342		.204	.294	.050	.12		.38
* 44RC1			B+ .402				.030	.06	.218	
* 44RC60	REC	REC	B+ .490				.050	.12		
* 44RC2	DIM. IN	DIM. IN		.50						
* 44RC61	1/16 THS	1/16 THS								
* 54RC1			B+ .514				.030	.06		
* 54RC60	REC	REC	B+ .534				.050	.12		
* 54RC2	DIM. IN	DIM. IN								
* 54RC61	1/16 THS	1/16 THS								
* 55RC1			B+ .514	.63	.281	.371	.030	.06		
* 55RC60	REC	REC	B+ .534				.050	.12		
* 55RC2	DIM. IN	DIM. IN								
* 55RC61	1/16 THS	1/16 THS							.312	.50
* 56RC1			B+ .514	.75			.030	.06		
* 56RC60	REC	REC	B+ .534				.050	.12		
* 56RC2	DIM. IN	DIM. IN								
* 56RC61	1/16 THS	1/16 THS								
* 65RC1			B+ .514	.63			.030	.06		
* 65RC60	REC	REC	B+ .534		.343	.433	.050	.12		
* 65RC2	DIM. IN	DIM. IN								
* 65RC61	1/16 THS	1/16 THS								
* 66RC1			B+ .514	.75			.030	.06		
* 66RC60	REC	REC	B+ .534				.050	.12		
* 66RC2	DIM. IN	DIM. IN								
* 66RC61	1/16 THS	1/16 THS								

J & M PART NO.	A DIM MIN .250	B DIM MIN .375	E +/- .015	W	H	HI	T	G	X	C RAD
* 75RC1			B+ .514	.63			.030	.06		
* 75RC60	REC	REC	B+ .534		.406	.496	.050	.12		.312 .50
* 75RC2	DIM. IN	DIM. IN								
* 75RC61	1/16 THS	1/16 THS								
* 76RC1			B+ .514				.030	.06		
* 76RC60	REC	REC	B+ .534				.050	.12		
* 76RC2	DIM. IN	DIM. IN								
* 76RC61	1/16 THS	1/16 THS								
* 86RC1			B+ .514	.75			.030	.06		** .375
* 86RC60	REC	REC	B+ .534				.050	.12		
* 86RC2	DIM. IN	DIM. IN								
* 86RC61	1/16 THS	1/16 THS								
* 88RC1			B+ .562	1.0	.468	.558	.040	.06	.437	
* 88RC60	REC	REC	B+ .582				.050	.12		.81
* 88RC2	DIM. IN	DIM. IN								
* 88RC61	1/16 THS	1/16 THS								
* 96RC1			B+ .623	.75			.030	.06		
* 96RC60	REC	REC	B+ .643		.531	.621	.050	.12		.375
* 96RC2	DIM. IN	DIM. IN								
* 96RC61	1/16 THS	1/16 THS								
* 98RC1			B+ .623	1.0			.040	.06	.437	
* 98RC60	REC	REC	B+ .643				.050	.12		
* 98RC2	DIM. IN	DIM. IN								
* 98RC61	1/16 THS	1/16 THS								

* Denotes Slotted Lower Foot ** 43RC1/43RC2/86RC1 Only - See Appendix For Materials, Finishes and Ordering Information.

SERIES SC - CLAMP, SADDLE, CUSHIONED

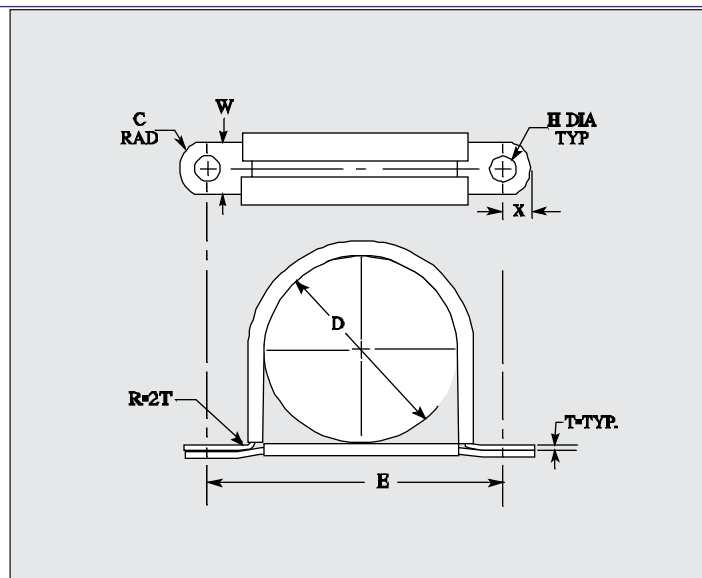

J&M PART NUMBER	D +/- .015	E +/- .015	W	H	T	X	C RAD
43SC1	-2 TO-16	.125 TO 1.000	D + .644	.375	.030	.188	.38
	-17 TO-96	1.062 TO 6.000	D + .684		.050		
44SC2	-2 TO-16	.125 TO 1.000	D + .804	.500	.030	.218	.38
	-17 TO-96	1.062 TO 6.000	D + .980		.050		
54SC1	-4 TO -8	.250 TO .500	D + 1.028	.281	.030	.312	.50
	-9 TO-16	.562 TO 1.000	D + 1.068		.050		
	-17 TO-96	1.062 TO 6.000	D + 1.068		.050		
55SC1 55SC6	-4 TO -8	.250 TO .500	D + 1.028	.63	.030	.312	.50
	-9 TO-16	.562 TO 1.000	D + 1.068		.050		
	-17 TO-96	1.062 TO 6.000	D + 1.068		.050		
56SC1	-4 TO -8	.250 TO .500	D + 1.028	.75	.030	.312	.50
	-9 TO-16	.562 TO 1.000	D + 1.068		.050		
	-17 TO-96	1.062 TO 6.000	D + 1.068		.050		
65SC1	-4 TO -8	.250 TO .500	D + 1.028	.63	.030	.343	.50
	-9 TO-16	.562 TO 1.000	D + 1.068		.050		
	-17 TO-96	1.062 TO 6.000	D + 1.068		.050		
66SC1	-4 TO -8	.250 TO .500	D + 1.028	.75	.030	.343	.50
	-9 TO-16	.562 TO 1.000	D + 1.068		.050		
	-17 TO-96	1.062 TO 6.000	D + 1.068		.050		

J&M PART NUMBER	D +/- .015	E +/- .015	W	H	T	X	C RAD
75SC1	-4 TO -8	.250 TO .500	D + 1.028	.63	.406	.030	.50
	-9 TO-16	.562 TO 1.000	D + 1.068		.050		
	-17 TO-96	1.062 TO 6.000	D + 1.068		.050		
76SC1	-4 TO -8	.250 TO .500	D + 1.028	.75	.030	.312	.50
	-9 TO-16	.562 TO 1.000	D + 1.068		.050		
	-17 TO-96	1.062 TO 6.000	D + 1.068		.050		
86SC1	-4 TO -8	.250 TO .500	D + 1.028	.468	.030	.375	.50
	-9 TO-16	.562 TO 1.000	D + 1.068		.050		
	-17 TO-96	1.062 TO 6.000	D + 1.068		.050		
88SC1	-4 TO -8	.250 TO .500	D + 1.124	1.0	.040	.437	.81
	-9 TO-16	.562 TO 1.000	D + 1.164		.050		
	-17 TO-96	1.062 TO 6.000	D + 1.164		.050		
96SC1	-4 TO -8	.250 TO .500	D + 1.246	.75	.040	.375	.50
	-9 TO-16	.562 TO 1.000	D + 1.286		.050		
	-17 TO-96	1.062 TO 6.000	D + 1.286		.050		
98SC1	-4 TO -8	.250 TO .500	D + 1.246	1.0	.040	.437	.50
	-9 TO-16	.562 TO 1.000	D + 1.286		.050		
	-17 TO-96	1.062 TO 6.000	D + 1.286		.050		

* See Appendix For Materials, Finishes and Ordering Information.

SERIES SC - CLAMP, RECTANGULAR SADDLE, CUSHION

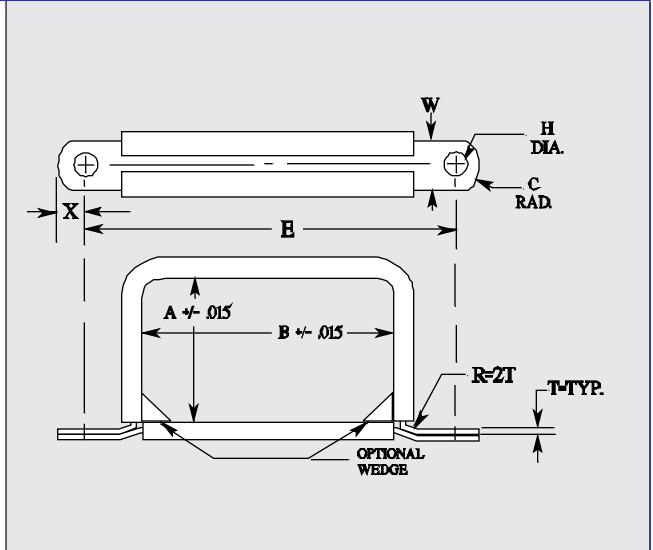

J&M PART #		A DIM MIN .250	B DIM MIN .375	E +/- .015	W	H	T	X	C RAD
43SC3	-2 TO-16	REC	REC	B+ .644	.375			.188	
	-17	DIM. IN	DIM. IN	B+ .684					
	TO-96	1/16 THS	1/16 THS						
44SC1	-2 TO-16	REC	REC	B+ .804				.218	.38
	-17	DIM. IN	DIM. IN	B+ .880					
	TO-96	1/16 THS	1/16 THS						
54SC5	-4 TO-8	REC	REC	B+ 1.028	.50				
	-9	DIM. IN	DIM. IN						
	TO-16	1/16 THS	1/16 THS						
55SC4	-4 TO-8	REC	REC	B+ 1.028		.281			
	-9	DIM. IN	DIM. IN						
	TO-16	1/16 THS	1/16 THS	B+ .63					
56SC7	-4 TO-8	REC	REC	B+ 1.028	.75			.312	.50
	-9	DIM. IN	DIM. IN						
	TO-16	1/16 THS	1/16 THS	B+ 1.068					
65SC2	-4 TO-8	REC	REC	B+ 1.028					
	-9	DIM. IN	DIM. IN						
	TO-16	1/16 THS	1/16 THS	B+ .63					
66SC6	-4 TO-8	REC	REC	B+ 1.028		.343	.050		
	-9	DIM. IN	DIM. IN						
	TO-16	1/16 THS	1/16 THS	B+ 1.068					

J&M PART NUMBER		A DIM MIN .250	B DIM MIN .375	E +/- .015	W	H	T	X	C RAD
75SC2	-4 TO-8	REC	REC	B+ 1.028	.63				
	-9	DIM. IN	DIM. IN						
	TO-16	1/16 THS	1/16 THS	B+ 1.068					
76SC3	-4 TO-8	REC	REC	B+ 1.028	.406			.312	.50
	-9	DIM. IN	DIM. IN						
	TO-16	1/16 THS	1/16 THS	B+ 1.068					
86SC2	-4 TO-8	REC	REC	B+ 1.028	.75	.468			.81
	-9	DIM. IN	DIM. IN						
	TO-16	1/16 THS	1/16 THS	B+ 1.068					
88SC3	-4 TO-8	REC	REC	B+ 1.124				.437	
	-9	DIM. IN	DIM. IN						
	TO-16	1/16 THS	1/16 THS	B+ 1.164					
96SC2	-4 TO-8	REC	REC	B+ 1.246	.75		.050		.375
	-9	DIM. IN	DIM. IN						
	TO-16	1/16 THS	1/16 THS	B+ 1.286					
98SC2	-4 TO-8	REC	REC	B+ 1.246	.531			.437	
	-9	DIM. IN	DIM. IN						
	TO-16	1/16 THS	1/16 THS	B+ 1.286					

* See Appendix For Materials, Finishes and Ordering Information.

SERIES LB- CLAMP, LOOP, NO CUSHION

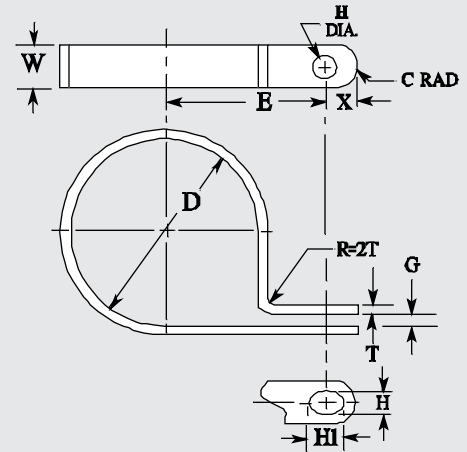

J&M PART NUMBER	D +/- .015	E +/- .015	W	H	H1	T	G	X	C RAD
* 43LB1 -2	.125	D/2	.375	.204	.294	.030	.06	**.188	.38
43LB6 TO -16	TO 1.000	+ .282							
-17 TO -96	TO 6.000	D/2 + .342							
* 44LB1 -2	.125	D/2	.500	.281	.371	.030	.06	.218	.50
44LB6 TO -16	TO 1.000	+ .430							
-17 TO -96	TO 6.000	D/2 + .490							
* 54LB1 -4	.250	D/2	.63	.343	.433	.030	.06	.312	.81
54LB6 TO -8	TO .500	+ .454							
-9 TO -16	TO 1.000								
-17 TO -96	TO 6.000	D/2 + .474				.050			
* 55LB1 -4	.250	D/2	.75	.343	.433	.030	.06	.312	.50
55LB6 TO -8	TO .500	+ .454							
-9 TO -16	TO 1.000								
-17 TO -96	TO 6.000	D/2 + .474				.050			
* 56LB1 -4	.250	D/2	.75	.343	.433	.030	.06	.312	.50
56LB6 TO -8	TO .500	+ .454							
-9 TO -16	TO 1.000								
-17 TO -96	TO 6.000	D/2 + .474				.050			
* 65LB1 -4	.250	D/2	.75	.343	.433	.030	.06	.312	.50
65LB6 TO -8	TO .500	+ .454							
-9 TO -16	TO 1.000								
-17 TO -96	TO 6.000	D/2 + .474				.050			
* 66LB1 -4	.250	D/2	.75	.343	.433	.030	.06	.312	.50
66LB6 TO -8	TO .500	+ .454							
-9 TO -16	TO 1.000								
-17 TO -96	TO 6.000	D/2 + .474				.050			

J&M PART NUMBER	D +/- .015	E +/- .015	W	H	H1	T	G	X	C RAD
* 75LB1 -4	.250	D/2	.63	.406	.496	.030	.12	.312	.50
75LB6 TO -8	TO .500	+ .454							
-9 TO -16	TO 1.000								
-17 TO -96	TO 6.000	D/2 + .474				.050			
* 76LB1 -4	.250	D/2	.75	.468	.558	.030	.06	.375	.81
76LB6 TO -8	TO .500	+ .454							
-9 TO -16	TO 1.000								
-17 TO -96	TO 6.000	D/2 + .474				.050			
* 86LB1 -4	.250	D/2	.75	.531	.621	.030	.06	.375	.81
86LB6 TO -8	TO .500	+ .502							
-9 TO -16	TO 1.000								
-17 TO -96	TO 6.000	D/2 + .522				.050			
* 88LB1 -4	.250	D/2	1.0	.531	.621	.030	.06	.437	.50
88LB6 TO -8	TO .500	+ .502							
-9 TO -16	TO 1.000								
-17 TO -96	TO 6.000	D/2 + .522				.050			
* 96LB1 -4	.250	D/2	.75	.531	.621	.030	.06	.375	.50
96LB6 TO -8	TO .500	+ .563							
-9 TO -16	TO 1.000								
-17 TO -96	TO 6.000	D/2 + .583				.050			
* 98LB1 -4	.250	D/2	1.0	.531	.621	.030	.06	.437	.50
98LB6 TO -8	TO .500	+ .563							
-9 TO -16	TO 1.000								
-17 TO -96	TO 6.000	D/2 + .583				.050			

* Denotes Slotted Lower Foot **43LB1 Only- See Appendix For Materials, Finishes and Ordering Information.

SERIES CB - CLAMP, CENTER MOUNT NO CUSHION

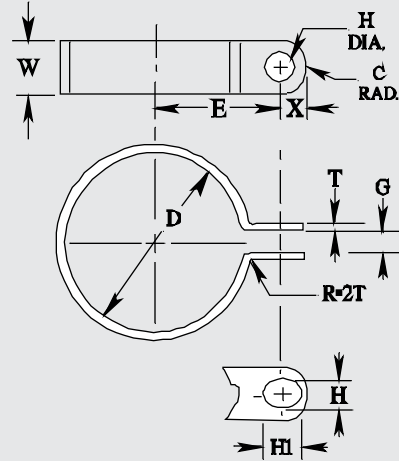

J&M PART NUMBER	D +/- .015	E +/- .015	W	H	H1	T	G	X	C RAD
43CC1	-2 TO -16 .125 TO 1.000	D/2 + .282	.375	.204	.294	.030	.06	.188	.38
	-17 TO -96 1.062 TO 6.000	D/2 + .302				.050	.12		
44CB1	-2 TO -16 .125 TO 1.000	D/2 + .342				.500	.281		
	-17 TO -96 1.062 TO 6.000	D/2 + .430	.050	.12					
54CB1	-4 TO -8 .250 TO .500	D/2 + .454	.63	.343	.433	.030	.06	.312	.50
	-9 TO -16 .562 TO 1.000	D/2 + .474				.050	.12		
	-17 TO -96 1.062 TO 6.000	D/2 + .474				.050	.12		
55CB1	-4 TO -8 .250 TO .500	D/2 + .454	.75	.343	.433	.030	.06	.312	.50
	-9 TO -16 .562 TO 1.000	D/2 + .474				.050	.12		
	-17 TO -96 1.062 TO 6.000	D/2 + .474				.050	.12		
56CB1	-4 TO -8 .250 TO .500	D/2 + .454	.75	.343	.433	.030	.06	.312	.50
	-9 TO -16 .562 TO 1.000	D/2 + .474				.050	.12		
	-17 TO -96 1.062 TO 6.000	D/2 + .474				.050	.12		
65CB1	-4 TO -8 .250 TO .500	D/2 + .454	.75	.343	.433	.030	.06	.312	.50
	-9 TO -16 .562 TO 1.000	D/2 + .474				.050	.12		
	-17 TO -96 1.062 TO 6.000	D/2 + .474				.050	.12		
66CB1 66CB6	-4 TO -8 .250 TO .500	D/2 + .454	.75	.343	.433	.030	.06	.312	.50
	-9 TO -16 .562 TO 1.000	D/2 + .474				.050	.12		
	-17 TO -96 1.062 TO 6.000	D/2 + .474				.050	.12		

J&M PART NUMBER	D +/- .015	E +/- .015	W	H	H1	T	G	X	C RAD
75CB1	-4 TO -8 .250 TO .500	D/2 + .454	.63	.406	.496	.030	.06	.312	.50
	-9 TO -16 .562 TO 1.000	D/2 + .474				.050	.12		
	-17 TO -96 1.062 TO 6.000	D/2 + .474				.050	.12		
76CB1	-4 TO -8 .250 TO .500	D/2 + .454	.75	.468	.558	.030	.06	.375	.81
	-9 TO -16 .562 TO 1.000	D/2 + .502				.050	.12		
	-17 TO -96 1.062 TO 6.000	D/2 + .522				.050	.12		
86CB1	-4 TO -8 .250 TO .500	D/2 + .502	1.0	.531	.621	.030	.06	.437	.81
	-9 TO -16 .562 TO 1.000	D/2 + .583				.050	.12		
	-17 TO -96 1.062 TO 6.000	D/2 + .583				.050	.12		
88CB1	-4 TO -8 .250 TO .500	D/2 + .502	1.0	.531	.621	.040	.06	.437	.81
	-9 TO -16 .562 TO 1.000	D/2 + .583				.050	.12		
	-17 TO -96 1.062 TO 6.000	D/2 + .583				.050	.12		
96CB1	-4 TO -8 .250 TO .500	D/2 + .563	.75	.531	.621	.030	.06	.375	.81
	-9 TO -16 .562 TO 1.000	D/2 + .583				.050	.12		
	-17 TO -96 1.062 TO 6.000	D/2 + .583				.050	.12		
98CB1	-4 TO -8 .250 TO .500	D/2 + .563	1.0	.531	.621	.040	.06	.437	.81
	-9 TO -16 .562 TO 1.000	D/2 + .583				.050	.12		
	-17 TO -96 1.062 TO 6.000	D/2 + .583				.050	.12		

* Denotes Slotted Lower Foot - See Appendix For Materials, Finishes and Ordering Information.

SERIES MB - CLAMP, MULTI-LOOP NO CUSHION

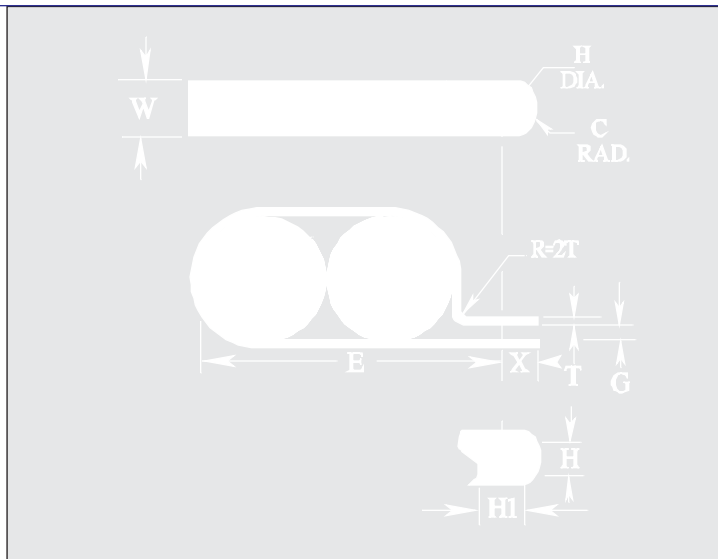

J&M PART NUMBER		D +/- .015	E +/- .015	W	H	H1	T	G	X	C RAD
* 43MB1	-2	.125 TO	DIA.X# OF	.375	.204	.294	.030	.06	**.188	.38
43MB6	TO-16	1.000	TUBE+.282							
	-17 TO-96	1.062 TO 6.000	DIA.X# OF TUBE+.302							
* 44MB1	-2	.125 TO	DIA.X# OF	.500	.281	.371	.030	.06	.218	.50
44MB6	TO-16	1.000	TUBE+.342							
	-17 TO-96	1.062 TO 6.000	DIA.X# OF TUBE+.430							
* 54MB1	-4	.250 TO	DIA.X# OF	.630	.281	.371	.030	.06	.312	.50
54MB6	TO -8	.500	TUBE+.454							
	-9 TO-16	.562 TO 1.000	DIA.X# OF TUBE+.474							
	-17 TO-96	1.062 TO 6.000	DIA.X# OF TUBE+.474				.050			
* 55MB1	-4	.250 TO	DIA.X# OF	.750	.343	.433	.030	.06	.312	.50
55MB6	TO -8	.500	TUBE+.454							
	-9 TO-16	.562 TO 1.000	DIA.X# OF TUBE+.474							
	-17 TO-96	1.062 TO 6.000	DIA.X# OF TUBE+.474				.050			
* 56MB1	-4	.250 TO	DIA.X# OF	.750	.343	.433	.030	.06	.312	.50
56MB6	TO -8	.500	TUBE+.454							
	-9 TO-16	.562 TO 1.000	DIA.X# OF TUBE+.474							
	-17 TO-96	1.062 TO 6.000	DIA.X# OF TUBE+.474				.050			
* 65MB1	-4	.250 TO	DIA.X# OF	.750	.343	.433	.030	.06	.312	.50
65MB6	TO -8	.500	TUBE+.454							
	-9 TO-16	.562 TO 1.000	DIA.X# OF TUBE+.474							
	-17 TO-96	1.062 TO 6.000	DIA.X# OF TUBE+.474				.050			
* 66MB1	-4	.250 TO	DIA.X# OF	.750	.343	.433	.030	.06	.312	.50
66MB6	TO -8	.500	TUBE+.454							
	-9 TO-16	.562 TO 1.000	DIA.X# OF TUBE+.474							
	-17 TO-96	1.062 TO 6.000	DIA.X# OF TUBE+.474				.050			

J&M PART NUMBER		D +/- .015	E +/- .015	W	H	H1	T	G	X	C RAD
* 75MB1	-4	.250 TO	DIA.X# OF	.63	.406	.496	.030	.06	.312	.50
75MB6	TO -8	.500	TUBE+.454							
	-9 TO-16	.562 TO 1.000	DIA.X# OF TUBE+.474							
	-17 TO-96	1.062 TO 6.000	DIA.X# OF TUBE+.474				.050			
* 76MB1	-4	.250 TO	DIA.X# OF	.75	.468	.558	.030	.06	.312	.50
76 MB6	TO -8	.500	TUBE+.454							
	-9 TO-16	.562 TO 1.000	DIA.X# OF TUBE+.474							
	-17 TO-96	1.062 TO 6.000	DIA.X# OF TUBE+.474				.050			
* 86MB1	-4	.250 TO	DIA.X# OF	1.0	.468	.558	.030	.06	.312	.50
86MB6	TO -8	.500	TUBE+.502							
	-9 TO-16	.562 TO 1.000	DIA.X# OF TUBE+.522							
	-17 TO-96	1.062 TO 6.000	DIA.X# OF TUBE+.522				.050			
* 88MB1	-4	.250 TO	DIA.X# OF	.75	.531	.621	.030	.06	.312	.50
88MB6	TO -8	.500	TUBE+.502							
	-9 TO-16	.562 TO 1.000	DIA.X# OF TUBE+.522							
	-17 TO-96	1.062 TO 6.000	DIA.X# OF TUBE+.522				.050			
* 96MB1	-4	.250 TO	DIA.X# OF	.75	.531	.621	.030	.06	.312	.50
96MB6	TO -8	.500	TUBE+.563							
	-9 TO-16	.562 TO 1.000	DIA.X# OF TUBE+.583							
	-17 TO-96	1.062 TO 6.000	DIA.X# OF TUBE+.583				.050			
* 98MB1	-4	.250 TO	DIA.X# OF	1.0	.531	.621	.030	.06	.312	.50
98MB6	TO -8	.500	TUBE+.563							
	-9 TO-16	.562 TO 1.000	DIA.X# OF TUBE+.583							
	-17 TO-96	1.062 TO 6.000	DIA.X# OF TUBE+.583				.050			

* Denotes Slotted Lower Foot ** 43MB2/86MB1 Only**See Appendix For Materials, Finishes and Ordering Information.

SERIES RB - CLAMP, RECTANGULAR LOOP, NO CUSHION

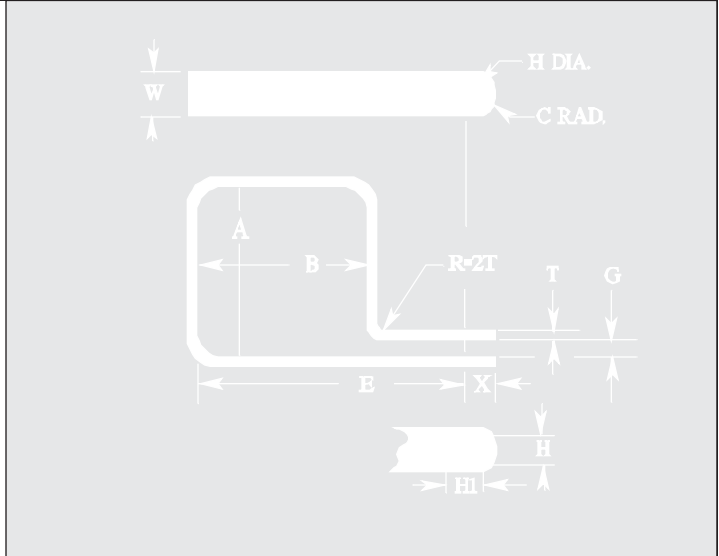

J&M PART #	A DIM MIN .250	B DIM MIN .375	E +/- .015	W	H	H1	T	G	X	C RAD
43RB1	REC DIM. IN	REC DIM. IN	B+ .262	.375	.204	.204	.030	.06	.188	.38
43RB2	1/16 THS	1/16 THS	B+ .282			.294	.050	.12		
44RB1	REC DIM. IN	REC DIM. IN	B+ .342	.50	.204	.204	.030	.06	.218	.312
44RB2	1/16 THS	1/16 THS	B+ .430			.294	.050	.12		
54RB1	REC DIM. IN	REC DIM. IN	B+ .454	.63	.281	.281	.030	.06	.312	.50
54RB2	1/16 THS	1/16 THS	B+ .474			.371	.050	.12		
55RB1	REC DIM. IN	REC DIM. IN	B+ .454	.63	.281	.281	.030	.06	.312	.50
55RB2	1/16 THS	1/16 THS	B+ .474			.371	.050	.12		
56RB1	REC DIM. IN	REC DIM. IN	B+ .454	.75	.281	.281	.030	.06	.312	.50
56RB2	1/16 THS	1/16 THS	B+ .474			.371	.050	.12		
65RB1	REC DIM. IN	REC DIM. IN	B+ .454	.63	.343	.281	.030	.06	.312	.50
65RB2	1/16 THS	1/16 THS	B+ .474			.433	.050	.12		
66RB1	REC DIM. IN	REC DIM. IN	B+ .454	.75	.343	.281	.030	.06	.312	.50
66RB2	1/16 THS	1/16 THS	B+ .474			.433	.050	.12		

J&M PART #	A DIM MIN .250	B DIM MIN .375	E +/- .015	W	H	H1	T	G	X	C RAD
75RB1	REC DIM. IN	REC DIM. IN	B+ .454	.63	.406	.406	.030	.06	.312	.50
75RB2	1/16 THS	1/16 THS	B+ .474			.496	.050	.12		
76RB1	REC DIM. IN	REC DIM. IN	B+ .454	.75	.406	.406	.030	.06	.312	.50
76RB2	1/16 THS	1/16 THS	B+ .474				.496	.050		
86RB1	REC DIM. IN	REC DIM. IN	B+ .454	1.0	.468	.468	.030	.06	.312	.50
86RB2	1/16 THS	1/16 THS	B+ .474				.558	.050		
88RB1	REC DIM. IN	REC DIM. IN	B+ .502	1.0	.468	.468	.040	.06	.312	.50
88RB2	1/16 THS	1/16 THS	B+ .522				.558	.050		
96RB1	REC DIM. IN	REC DIM. IN	B+ .563	.75	.531	.531	.030	.06	.312	.50
96RB2	1/16 THS	1/16 THS	B+ .583				.621	.050		
98RC1	REC DIM. IN	REC DIM. IN	B+ .563	1.0	.531	.531	.040	.06	.312	.50
98RB2	1/16 THS	1/16 THS	B+ .583				.621	.050		

- See Appendix For Materials, Finishes and Ordering Information.

SERIES SB - CLAMP, SADDLE, CUSHIONED

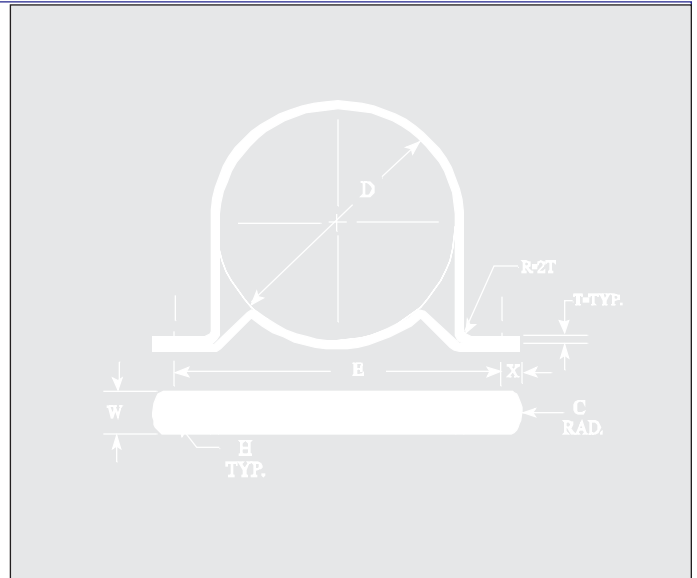

J&M PART NUMBER	D +/- .015	E +/- .015	W	H	T	X	C RAD
43SB1	-2 TO-16	.125 TO 1.000	D+ .564	.375	.030	.188	.38
	-17 TO-96	1.062 TO 6.000	D+ .684		.050		
					.204		
44SB10	-2 TO-16	.125 TO 1.000	D+ .684	.500	.030	.218	.38
	-17 TO-96	1.062 TO 6.000	D+ .860		.050		
					.281		
54SB2	-4 TO-8	.250 TO .500	D+ .908	.281	.030	.030	.50
	-9 TO-16	.562 TO 1.000	D+ .948		.050		
	-17 TO-96	1.062 TO 6.000	D+ .948		.050		
55SB2	-4 TO-8	.250 TO .500	D+ .908	.63	.030	.312	.50
	-9 TO-16	.562 TO 1.000	D+ .948		.050		
	-17 TO-96	1.062 TO 6.000	D+ .948		.050		
56SB2	-4 TO-8	.250 TO .500	D+ .908	.75	.030	.030	.50
	-9 TO-16	.562 TO 1.000	D+ .948		.050		
	-17 TO-96	1.062 TO 6.000	D+ .948		.050		
65SB2	-4 TO-8	.250 TO .5000	D+ .908	.63	.030	.343	.050
	-9 TO-16	.562 TO 1.000	D+ .948		.050		
	-17 TO-96	1.062 TO 6.000	D+ .948		.050		
66SB2	-4 TO-8	.250 TO .500	D+ .908	.75	.030	.030	.050
	-9 TO-16	.562 TO 1.000	D+ .948		.050		
	-17 TO-96	1.062 TO 6.000	D+ .948		.050		

J&M PART NUMBER	D +/- .015	E +/- .015	W	H	T	X	C RAD
75SB2	-4 TO-8	.250 TO .500	D+ .908	.63	.406	.030	.312
	-9 TO-16	.562 TO 1.000	D+ .948		.050		
	-17 TO-96	1.062 TO 6.000	D+ .948		.050		
76SB2	-4 TO-8	.250 TO .500	D+ .908	.75	.030	.030	.50
	-9 TO-16	.562 TO 1.000	D+ .948		.050		
	-17 TO-96	1.062 TO 6.000	D+ .948		.050		
86SB2	-4 TO-8	.250 TO .500	D+ 1.004	.468	.030	.375	.81
	-9 TO-16	.562 TO 1.000	D+ 1.044		.050		
	-17 TO-96	1.062 TO 6.000	D+ 1.044		.050		
88SB2	-4 TO-8	.250 TO .500	D+ 1.004	1.0	.040	.437	.81
	-9 TO-16	.562 TO 1.000	D+ 1.1044		.050		
	-17 TO-96	1.062 TO 6.000	D+ 1.1044		.050		
96SB2	-4 TO-8	.250 TO .500	D+ 1.126	.75	.040	.375	.531
	-9 TO-16	.562 TO 1.000	D+ 1.166		.050		
	-17 TO-96	1.062 TO 6.000	D+ 1.166		.050		
98SB2	-4 TO-8	.250 TO .500	D+ 1.126	1.0	.040	.437	.050
	-9 TO-16	.562 TO 1.000	D+ 1.166		.050		
	-17 TO-96	1.062 TO 6.000	D+ 1.166		.050		

* See Appendix For Materials, Finishes and Ordering Information.

SERIES SB - CLAMP, RECTANGULAR SADDLE, NO CUSHION

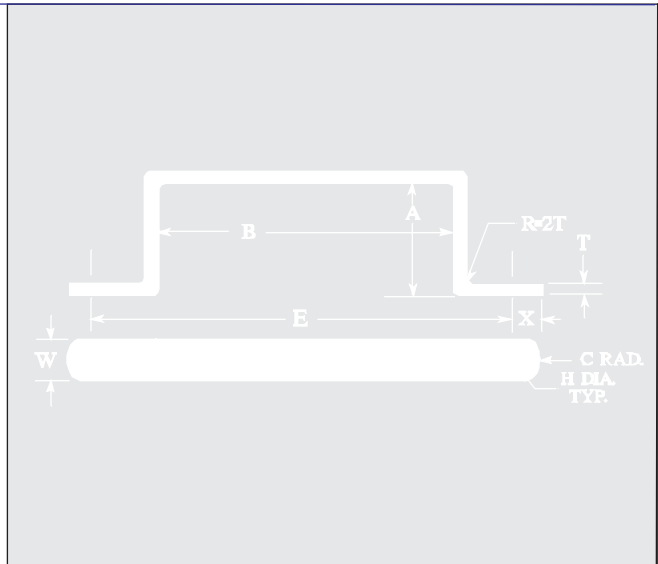

J&M PART #		A DIM MIN. .250	B DIM MIN. .375	E +/- .015	W	H	T	X	C RAD
43SB1	-2	REC	REC	B + .584	.375	.204	.030	.188	.30
	TO-16	DIM. IN	DIM. IN	B + .604					
	TO-96	1/16 THS	1/16 THS						
44SB9	-2	REC	REC	B + .684	.50			.218	
	TO-16	DIM. IN	DIM. IN	B + .760					
	TO-96	1/16 THS	1/16 THS						
54SB1	-4	REC	REC	B + .908			.040		
	TO-8	DIM. IN	DIM. IN	B + .948					
	TO-16	1/16 THS	1/16 THS						
55SB1	-4	REC	REC	B + .908	.63	.281			
	TO-8	DIM. IN	DIM. IN	B + .948					
	TO-16	1/16 THS	1/16 THS						
56SB1	-4	REC	REC	B + .908	.75			.312	.50
	TO-8	DIM. IN	DIM. IN	B + .948					
	TO-16	1/16 THS	1/16 THS						
65SB1	-4	REC	REC	B + .908	.63				
	TO-8	DIM. IN	DIM. IN	B + .948					
	TO-16	1/16 THS	1/16 THS						
66SB1	-4	REC	REC	B + .908		.343	.050		
	TO-8	DIM. IN	DIM. IN	B + .948					
	TO-16	1/16 THS	1/16 THS						

J&M PART NUMBER		A DIM MIN. .250	B DIM MIN. .375	E +/- .015	W	H	T	X	C RAD
75SB1	-4	REC	REC	B + .908	.63				
	TO-8	DIM. IN	DIM. IN	B + .948					
	TO-16	1/16 THS	1/16 THS						
76SB1	-4	REC	REC	B + .908		.406		.312	.50
	TO-8	DIM. IN	DIM. IN	B + .948					
	TO-16	1/16 THS	1/16 THS						
86SB1	-4	REC	REC	B + .908	.75	.468	.050	.375	.81
	TO-8	DIM. IN	DIM. IN	B + .948					
	TO-16	1/16 THS	1/16 THS						
88SB1	-4	REC	REC	B + 1.004	1.0			.437	
	TO-8	DIM. IN	DIM. IN	B + 1.044					
	TO-16	1/16 THS	1/16 THS						
96SB1	-4	REC	REC	B + 1.126	.75			.375	
	TO-8	DIM. IN	DIM. IN	B + 1.146					
	TO-16	1/16 THS	1/16 THS						
98SB1	-4	REC	REC	B + 1.126	1.0	.531		.437	
	TO-8	DIM. IN	DIM. IN	B + 1.146					
	TO-16	1/16 THS	1/16 THS						

* See Appendix For Materials, Finishes and Ordering Information.

AS4149

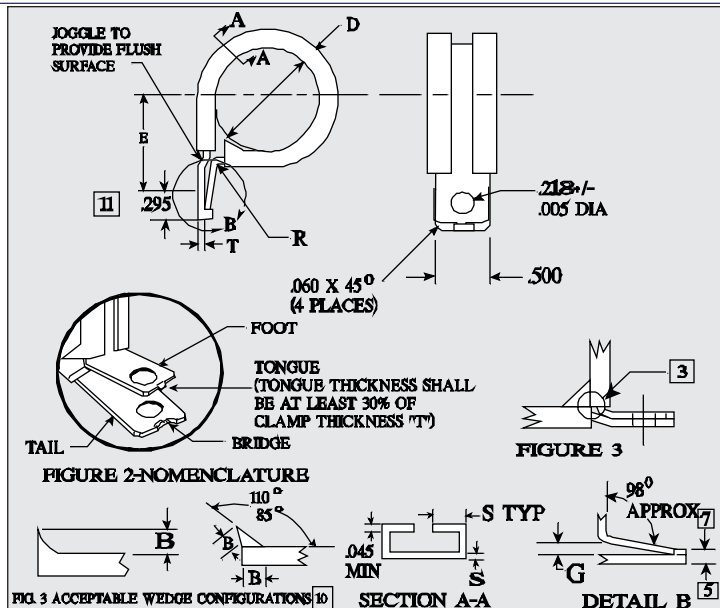

AS4149 PART NUMBER	RIGID TUBE NOMINAL DIAMETER	B	D DIA	E	GAP		R +/- .016	S +.020 -0.000	T
					6.3 G1	6.5 G2			
AS4149()-4	1/4		0.250	0.529					
AS4149()-5	5/16		0.313	0.560	.06		.062		.032
AS4149()-6	3/8	.093	0.375	0.592	+.04				+/-
AS4149()-7	7/16	.125	0.483	0.623	-0.00		.062		.0025
AS4149()-8	1/2		0.500	0.654			+.016	.040	
AS4149()-9	9/16		0.563	0.752			-0.000		
AS4149()-10	5/8		0.625	0.783					
AS4149()-11	11/16		0.688	0.814	.06				
AS4149()-12	3/4		0.750	0.845	+.06				
AS4149()-13	13/16		0.813	0.877	-0.00		.109		.050
AS4149()-14	7/8		0.875	0.908					+/-
AS4149()-15	15/16		0.938	0.939					.004
AS4149()-16	1.0		1.000	0.970					
AS4149()-17	1-1/16		1.063	1.002					
AS4149()-18	1-1/8		1.125	1.062					
AS4149()-19	1-3/16		1.188	1.093					
AS4149()-20	1-1/4		1.250	1.124					
AS4149()-21	1-15/16		1.313	1.156					
AS4149()-22	1-3/8		1.375	1.187					
AS4149()-23	1-7/16		1.438	1.218					
AS4149()-24	1-1/2		1.500	1.249					
AS4149()-25	1-9/16		1.563	1.281	.09	.094			
AS4149()-26	1-5/8		1.625	1.312	+.06	+.031			
AS4149()-27	1-11/16		1.688	1.344	-0.00	-0.000			
AS4149()-28	1-3/4	.155	1.750	1.374					
AS4149()-29	1-13/16	.0312	1.183	1.406					
AS4149()-30	1-7/8		1.875	1.437					
AS4149()-31	1-15/16		1.938	1.468					
AS4149()-32	2.0		2.000	1.499					
AS4149()-33	2-1/16		2.062	1.531			.125		.062
AS4149()-34	2-1/8		2.125	1.562				.060	+/-
AS4149()-35	2-3/16		2.188	1.594	.12	.125			.00
AS4149()-36	2-1/4		2.250	1.624	+.06	+.031			
AS4149()-37	2-5/16		2.312	1.655	-0.00	-0.000			
AS4149()-38	2-3/8		2.375	1.687					
AS4149()-40	2-1/2		2.500	1.752					
AS4149()-42	2-5/8		2.625	1.812					
AS4149()-43	2-11/16		2.688	1.844					
AS4149()-44	2-3/4		2.750	1.875					
AS4149()-45	2-13/16		2.812	1.906					
AS4149()-46	2-7/8		2.875	1.937					
AS4149()-48	3.0		3.000	2.000					
AS4149()-50	3-1/8		3.125	2.062					
AS4149()-52	3-1/4		3.250	2.125					
AS4149()-54	3-3/8		3.375	2.187					
AS4149()-56	3-1/2	NO WEDGE	3.500	2.250					
AS4149()-58	3-5/8		3.625	2.312					
AS4149()-64	4.0		4.000	2.500					
AS4149()-66	4-1/8		4.125	2.562					

* Ordering Information & Notes See Reverse Side of Page.

AS4149

NOTES

MATERIALS:

BAND- Aluminum Alloy-See Procurement Specification

Cushion- Ethylene Propylene
Nitrile
Chloroprene
See Procurement Specification

Finish Alcad, Chemical Conversion Coating
See Procurement Specification

MATERIAL CODES

Letter (S) indicates band and cushion materials. Do not specify band/cushion combinations not listed. Maximum recommended temperature is indicated in parentheses.

DE = Aluminum Band with Ethylene Propylene Cushion (212°F)
DF = Aluminum Band with Nitrile Cushion (212°F)
DG = Aluminum Band with Chloroprene Cushion (212°F)

EXAMPLE OF PART NO:

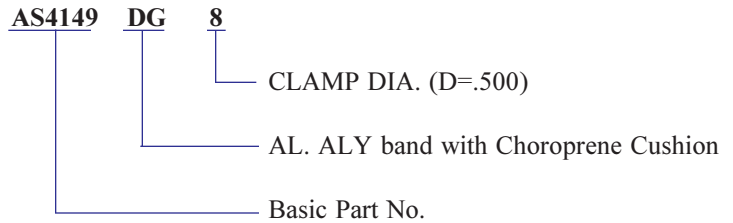

NOTES:

1. This standard takes precedence over documents referenced herein.
2. Remove all burrs and sharp edges.
3. The ends of the cushion shall meet when the clamp is in the installed position.
4. Clamps shall be furnished in the open position.
5. Height of the bridge shall not exceed two times minimum strap thickness.
6. Operation - Clamps shall be formed such that closure and locking can be accomplished with simple manipulation using a plier type installation tool. It shall be possible to engage the locking feature by hand. Each lot of clamps shall be inspected to verify the conditions imposed in 6.3, 6.4 and 6.5 are met.
 - 6.1 INSPECTION LOT - Inspection is defined as all those clamps of the same part number formed on the same set-up during a continuous production run.
 - 6.2 SAMPLING - A random sample shall be selected from each inspection lot in accordance with MIL-STD-105, Inspection Level 1, with an AQL of 4.0 percent.
 - 6.3 FREE STATE CLOSURE - Clamps shall be closed and locked. The angle between foot and tail shall be such that the resultant gap (when measured as shown in detail B) conforms to Dimension G1. Mounting holes shall align such that a #10 fastener will be accepted through both holes. Foot and tail shall remain positively locked and disengage only when the front of the clamp is depressed to allow the tongue to clear the bridge.
 - 6.4 CLOSURE OVER MANDREL - The clamp shall be installed over a mandrel of D diameter +/- .001, closed and locked. Clamps shall meet all requirements specified for Free State Closure per 6.3.
 - 6.5 FIXTURE TEST-Clamps shall be installed over a mandrel of D diameter +/- .001 and placed in a fixture designed to enable verification of the "Closure Test" Requirements of MIL-C-8603. Clamps shall meet the closure test requirements without engagement of the locking feature. GAP G2 is applicable for this test.
7. The clamp shall be formed with an angle approaching 98° during manufacture. This dimension is "For Reference Only" for finished clamps.
8. Procurement specification: Except as otherwise specified herein, clamps shall meet and be furnished in accordance with the requirements of MIL-C-8603.
9. Cushion application and color information.
 - 9.1 Ethylene Propylene - For use in areas contaminated with Phosphate Ester Hydraulic Fluid and other Synthetic Fluids. Excellent Ozone resistance. Not resistant to Petroleum Based Fluids. Color shall be Solid Purple.
 - 9.2 Nitrile - For use primarily in fuel immersion and vapors. Good Ozone resistance. Not resistant to Phosphate Ester Based Fluids. Not for use on Titanium Tubing. Color shall be Solid Yellow.
 - 9.3 Chloroprene - For general purpose use in areas contaminated with petroleum based hydraulic fluids and occasional fuel splash. Excellent Ozone resistance. Not resistant to Phosphate Ester Based Fluids. Not for use on Titanium Tubing. Color shall be Black with a Blue Identifier per the procurement specification.
10. Wedge is mandatory for -4 thru -48 size clamps. Wedge is prohibited on -50 thru -66 clamps. Wedge shall be integrally molded to cushion or vulcanized using pressure and heat to accomplish a bond between cushion and wedge. Wedge shall overlap and touch opposite end of cushion when clamp mounting holes are aligned and dimension G is 0.00 (clamp completely closed).
11. These clamps are identical to MS21919 Clamps for applicable sizes and materials shown except for the addition of an integral locking feature that permits the clamp ends to be locked together prior to insertion of the fastener. Note that the .295 dimension exceeds the "X" dimension of .218 on MS21919.
12. All dimensions are in inches. Tolerances unless otherwise specified: Decimals +/- .015

ORDERING INFORMATION & NOTES

AS4149

* APPLICABLE NOTES SEE AS4149

MS21919

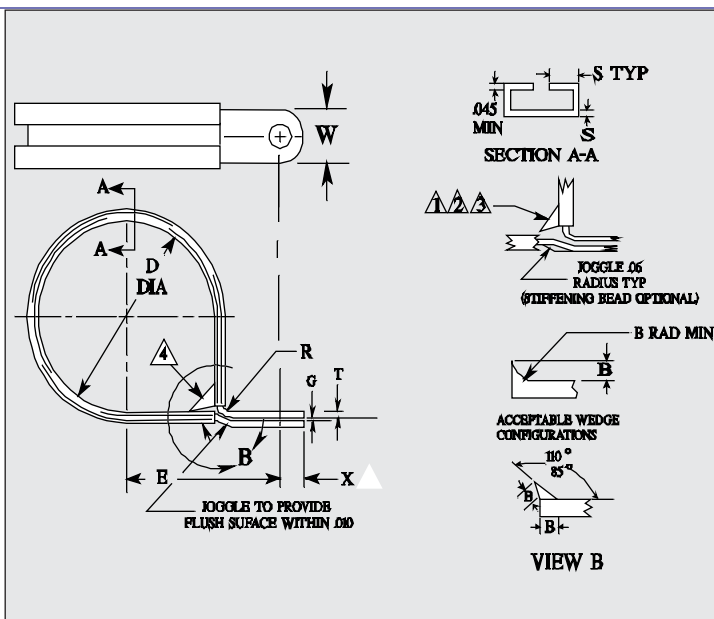
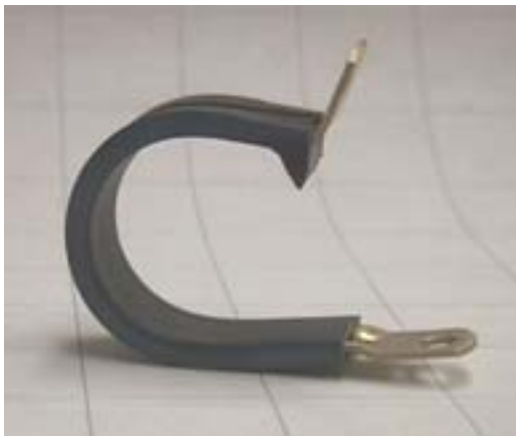

AS4149 NOMINAL	RIGID TUBE DIA	B	D DIA	E +/- .015		G	R +/- -.016	S +.020 -.000	T		W +/- .010		X +/- .015	
				ALUM	STEEL & CRES				ALUM	STEEL & CRES	ALUM	STEEL & CRES	ALUM	STEEL & CRES
MS21919()-1	1/16	△	0.062	0.436	0.436	0.062 + .016 - .000	0.062	0.040	0.020	0.020	0.375	0.188	0.188	
MS21919()-2	1/8	.046	0.125	.0457	.0457									
MS21919()-3	3/16	0.110	0.188	0.498	0.498									
MS21919()-4	1/4	0.093 0.125	0.250	0.529	0.529									
MS21919()-5	5/16		0.313	0.560	0.560									
MS21919()-6	3/8		0.375	0.592	0.592									
MS21919()-7	7/16		0.483	0.623	0.623									
MS21919()-8	1/2	0.500	0.654	0.654	0.109				0.050	0.050	0.375			0.188
MS21919()-9	9/16	0.563	0.752	0.749										
MS21919()-10	5/8	0.625	0.783	0.780										
MS21919()-11	11/16	0.688	0.814	0.811										
MS21919()-12	3/4	0.750	0.845	0.842										
MS21919()-13	13/16	0.813	0.877	0.858										
MS21919()-14	7/8	0.875	0.908	0.889										
MS21919()-15	15/16	0.938	0.939	0.920										
MS21919()-16	1.0	1.000	0.970	0.951										
MS21919()-17	1-1/16	1.063	1.002	0.983										
MS21919()-18	1-1/8	0.155 0.312	1.125	1.062	1.030	0.094 +0.031 -.000	0.125	0.060	.032	0.500	0.218	.0218		
MS21919()-19	1-3/16		1.188	1.093	1.061									
MS21919()-20	1-1/4		1.250	1.124	1.092									
MS21919()-21	1-5/16		1.313	1.156	1.124									
MS21919()-22	1-3/8		1.375	1.187	1.155									
MS21919()-23	1-7/16		1.438	1.218	1.186									
MS21919()-24	1-1/2		1.500	1.249	1.217									
MS21919()-25	1-9/16		1.563	1.281	1.259									
MS21919()-26	1-5/8		1.625	1.312	1.280									
MS21919()-27	1-11/16		1.688	1.344	1.312									
MS21919()-28	1-3/4	1.750	1.374	1.342										
MS21919()-29	1-13/16	1.813	1.406	1.374										
MS21919()-30	1-7/8	1.875	1.437	1.405										
MS21919()-31	1-15/16	△	1.938	1.468	1.444	0.125 + .031 - .000	0.125	0.060	0.062	0.500	0.218	.0218		
MS21919()-32	2.0		2.000	1.499	1.475									
MS21919()-33	2-1/16		2.062	1.531	1.507									
MS21919()-34	2-1/8		2.216	1.562	1.538									
MS21919()-35	2-3/16		2.188	1.594	1.570									
MS21919()-36	2-1/4		2.250	1.624	1.600									
MS21919()-37	2-5/16		2.312	1.655	1.631									
MS21919()-38	2-3/8		2.375	1.687	1.663									
MS21919()-40	2-1/2		2.500	1.752	1.728									
MS21919()-42	2-5/8		2.625	1.812	1.788									
MS21919()-43	2-11/16	2.688	1.844	1.820										
MS21919()-44	2-3/4	2.750	1.875	1.851										
MS21919()-45	2-13/16	2.812	1.906	1.882										
MS21919()-46	2-7/8	2.875	1.937	1.913										
MS21919()-48	3	3.000	2.000	1.976										
MS21919()-50	3-1/8	△	3.125	2.062	2.038	0.125 + .031 - .000	0.125	0.060	0.040	0.500	0.218	.0218		
MS21919()-52	3-1/4		3.250	2.125	2.101									
MS21919()-54	3-3/8		3.375	2.187	2.163									
MS21919()-56	3-1/2		3.500	2.250	2.226									
MS21919()-58	3-5/8		3.625	2.312	2.288									
MS21919()-64	4.0		4.000	2.500	2.476									
MS21919()-66	4-1/8		4.125	2.562	2.538									

* Ordering Information & Notes See Reverse Side of Page.

MS21919

NOTES

REQUIREMENT:

1. MATERIALS:

BAND - Aluminum Alloy
Corrosion Resistant Steel
Low Carbon Steel

CUSHION - Ethylene Propylene SEE MIL-C-8603
Nitrile
Chloroprene
Silicone
Fluorosilicone

2. FINISH:

Chemical Conversion
Passivated SEE MIL-C-8603
Cadmium Plated

3. MATERIAL CODES:

Letter(s) indicate band and cushion materials. Do not specify band/cushion combination not listed. Maximum recommended temperature is indicated in parenthesis.

DE - Aluminum Band with Ethylene Propylene Cushion (212°F)
DF - Aluminum Band with Nitrile Cushion (212°F)
DG - Aluminum Band with Chloroprene Cushion (212°F)
CE - Cres Band with Ethylene Propylene Cushion (275°F)
CF - Cres Band with Nitrile Cushion (212°F)
CH - Cres Band with Silicone Cushion (400°F)
CG - Cres Band with Chloroprene Cushion (212°F)
CJ - Cres Band with Fluorosilicone Cushion (450°F)
F - Low Carbon Steel Band with Nitrile Cushion (212°F)
G - Low Carbon Steel Band with Chloroprene Cushion (212°F) 
H - Low Carbon Steel Band with Silicone Cushion (400°F)

4. CUSHION APPLICATION INFORMATION

Ethylene Propylene - For use in areas contaminated with Phosphate Ester Hydraulic Fluids. Color shall be Solid Purple.

Nitrile - For use primarily in Fuel Immersion and Fuel Vapors. Good Ozone resistance. Not resistant to Phosphate Ester Based Fluids. Not for use on Titanium Tubing. Color shall be Solid Yellow.

Chloroprene - For General Purpose Use in areas contaminated with Petroleum Based Hydraulic Fluids and occasional fuel splash. Excellent Ozone resistance. Not resistant to Phosphate Based Fluids. Not for use on Titanium Tubing. Color shall be Black with a Blue Identifier per MIL-C-8603.







Silicone - For Elevated Temperature Usage in Phosphate Ester Based Fluids and other synthetic fluid contaminated areas. Unaffected by Ozone. Not resistant to Petroleum Based Fluids. Color shall be Natural White.

Fluorosilicone - For Elevated Temperature Usage in petroleum based fluid contaminated areas. Unaffected by Ozone. Not resistant to Phosphate Ester Based Fluids. Color shall be Solid Blue

ORDERING INFORMATION & NOTES

* For Applicable Notes See MS21919.

NOTES:

-  Letter "W" indicates wedge type cushion. Wedge (W) is mandatory for -2 thru -48 size clamps.
-  Wedge is prohibited on -1 and thru -50 thru -66 size clamps.
-  Wedge shall be integrally molded to cushion or vulcanized using pressure and heat to accomplish a bond between cushion and wedge.
-  Wedge shall overlap and touch opposite end of cushion when clamp mounting holes are aligned and dimension G is 0.00 (clamp completely closed).
5. The clamp band shall be finished during manufacture such as to remove all tool marks, sharp edges and burrs.
-  Clamps with Low Carbon Steel Bands are inactive for new aircraft design as of 1 October 1982.
-  Cancelled P/N's listed in interchangeability table are cancelled after 1 October 1982. Replacement P/N's can replace cancelled P/N's universally but canceled P/N cannot replace replacement P/N universally.
8. Dimensions are in inches.
9. Intended use: These clamps are intended for general purpose clamping applications including Electrical Wire Bundle Clamping. For high performance loop style clamps for use in MIL-H-5440 Hydraulic systems see MIL-C-85052.

10. Example Part Numbers:

For -2 thru -48 Size Clamps (Wedge Mandatory) 

MS21919 WDG 8

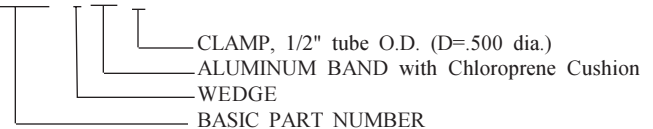

For -50 thru -66 size clamps (Wedge Prohibited) 



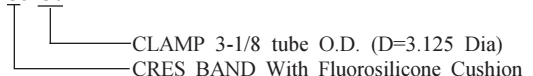



MS21919 CJ 50



11. Referenced documents shall be of the issue in effect on date of the invitations for bids or request for proposal. Except that referenced adopted industry documents shall give the date of issue adopted.

12. For design feature purposes. This standard takes precedence over procurement documents referenced herein.

INTERCHANGEABILITY TABLE

For -2 Thru -48	Cancelled Part No	Replacement Part No.
	MS21919WB(F,G,H) ()	MS21919W(F,G,H) () 
	MS21919B(F,G,H) ()	MS21919W(F,G,H) () 
	MS21919D(F,G) ()	MS21919WD(F,G) ()
	MS21919C(F,G,H) ()	MS21919WC(F,G,H) () 
	MS21919(F,G,H) ()	MS21919W(F,G,H) () 
	MS21919DH ()	MS21919WCH ()
	MS21919WDH ()	MS21919WCH ()
For -50 Thru -66	CANCELLED PART NO.	REPLACEMENT PART NO.
	MS21919WC(F,G,H) ()	MS21919C(F,G,H) ()
	MS21919WD(F,G) ()	MS21919D(F,G) ()
	MS21919WB(F,G,H) ()	MS21919(F,G,H) () 
	MS21919B(F,G,H) ()	MS21919(F,G,H) () 
	MS21919DH ()	MS21919CH ()
	MS21919WDH ()	MS21919CH ()
	MS21919(F,G,H) ()	MS21919(F,G,H) () 

NOTE: Insert Appropriate (Dash No.) In Parenthesis At End Of Part Number.

M85052

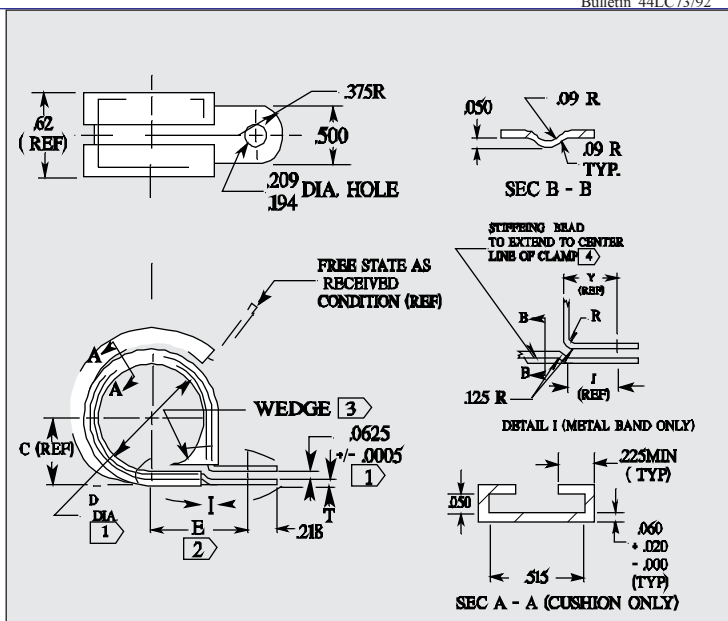

M85052	RIGID TUBE NOMINAL	C (REF)	D DIA (1)	E (2)	J (REF)	R +/- .010	T	Y (REF)
M85052/()-02()	1/8	.192	.125	.468	.235	.090	.020 +/- .002	.325
M85053/()-03()	3/16	.224	.188	.468				
M85053/()-04()	1/4	.255	.250	.530				
M85053/()-05()	5/16	.286	.312	.561				
M85053/()-06()	3/8	.318	.375	.592				
M85053/()-07()	7/16	.349	.438	.624				
M85053/()-08()	1/2	.360	.500	.655	.256	.125	.032 +/- .002	.368
M85053/()-09()	9/16	.423	.562	.741				
M85053/()-10()	5/8	.454	.625	.772				
M85053/()-11()	11/16	.486	.688	.804				
M85053/()-12()	3/4	.517	.750	.835				
M85053/()-13()	13/16	.548	.812	.866				
M85053/()-14()	7/8	.580	.875	.898	.262	.040 +/- .003	.370	
M85053/()-15()	15/16	.611	.938	.929				
M85053/()-16()	1.0	.642	1.000	.960				
M85053/()-17()	1-1/16	.681	1.062	1.001				
M85053/()-18()	1-1/8	.712	1.125	1.032				
M85053/()-19()	1-3/16	.744	1.188	1.064				
M85053/()-20()	1-1/4	.775	1.250	1.095	.262	.040 +/- .003	.370	
M85053/()-21()	1-5/16	.806	1.312	1.126				
M85053/()-20()	1-3/8	.838	1.375	1.158				
M85053/()-23()	1-7/16	.869	1.438	1.189				
M85053/()-24()	1-1/2	.900	1.500	1.220				

M85052

NOTES

- 1 Diameter "D" is the nominal diameter for which a clamp size is intended for use. Diameter "D" shall be verified by testing per MIL-C-85052 paragraph 3.5.3.1.
- 2 Dimension "E" shall be measured with clamp installed on a mandrel of "D" +/- .001 and a .0625 +/- .0625 spacer between upper and lower foot.
- 3 Wedge shall be required on size -6 and larger. The wedge shall be molded as an integral part of the cushion and contoured to fit "D" diameter.
- 4 Stiffening bead shall be required on size -4 and larger. All radii on the stiffening bead shall be smooth and blended. No sharp tool marks are allowed.
- 5 Unless otherwise specified, dimensions are in inches.
- 6 Metal bands shall have all burrs, sharp edges and scale removed.
- 7 Wedge shall touch cushion on lower foot with clamp installed on mandrel without spacer.
- 8 Reference dimensions "Y" and "J" are provided to gain maximum support for the lower foot by closely fitting the upper foot bend radius to the stiffening bead bend radius when closed against each other.

METAL CODE:

PH=17-7 PH. Corrosion resistant Steel per AMS 5528. Annealed, stress relieved and heat treated to TH1100 condition per MIL-H-6875 after forming.

CUSHION CODE:

YN (/1): Yellow Nitrile Butadiene Rubber, 65-75 durometer, color Yellow, per MIL-C-85052 and MIL-C-85052/1.



ET (/2): Ethylene Propylene Rubber, 65-75 durometer, color Purple, per MIL-C-85052 and MIL-C-85052/2.









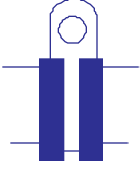
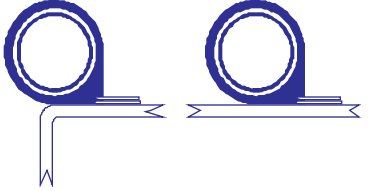





SF (/3): Fabric Reinforced Silicone Rubber, 65-75 durometer on unreinforced material. Color Light Blue per MIL-C-85052 and MIL-C-85052/3. The fabric reinforcing material shall be molded into the band side of the clamp cushion at a 45° angle.

MARKINGS: The complete standard part number and manufacturer's name, trademark, or FSCM number shall be impression stamped on the band in an area not covered by the cushion. All markings shall be above the tube theoretical centerline. Clamp bands of -2, -3, -4 sizes may be marked with the manufacturer's identification, the size, and the specification sheet due to space limitations.

SAMPLE CALLOUT



METAL IDENTIFICATION CODES		TUBE INSTALLATION		
CM	4130 ALLOY STEEL, PER MIL-S-17829 AND AMS 6350, ANNEALED	 <p>FIT: Proper fit of tubes to clamps is essential to insure maximum life of clamps and tubes (fig. 1).</p>  <p>Undersized tubes will allow contaminants to enter between the clamp and tube wall. This will result in excessive wear of the tube wall minimizing tube life (fig. 2).</p>  <p>Oversized tubes installed in an improperly sized clamp will cause deformation of the clamp foot that will result in excessive stress that can cause metal fatigue and clamp failure (fig. 3).</p>  <p>POSITION: The position of the clamp and tube when installed should be at right angles (90°). This will prevent unnecessary wear to the clamp cushion and tube wall (fig. 4.).</p>  <p>MOUNTING: It is recommended when installing clamps that loads applied to the clamp be in a manner as to maximize the structural integrity of the clamp to the parent structure. This will insure maximum clamp longevity (fig. 5).</p>		
CS	1095 SPRING STEEL			
D	2024-T4 ALUMINUM ALLOY, PER QQ-A-250/5, HEAT TREAT PER MIL-H-6088.			
DC	2024-0 ALUMINUM ALLOY, PER QQ-A-250/5. HEAT TREAT TO CONDITION T42 PER MIL-H-6088. CHEM FILM PER MIL-C-5541.			
DA	2024-0 PER QQ-A-250/5, HEAT TREAT TO CONDITION T42 PER MIL-H-6088, ANODIZE PER MIL-A-8625, TYPE I, CLASS I.			
H	321 CRES PER AMS 5510, BALL BURNISHED AND PASSIVATED PER QQ-P-35 TYPE VI OR VIII.			
PH	17-7 PH CRES, ANNEALED PER AMS 5528 HEAT TREAT TO CONDITION TH1100 PER MIL-H-6875, BALL BURNISHED AND PASSIVATED PER QQ-P-35.			
S	1010-4 OR BETTER STEEL, CADMIUM PLATE, PER QQ-P-416, TYPE I, CLASS 2, PER ASTM-A-366, ASTM-A-698 AND ASTM-A-109			
SS	302/304 CRES, PER AMS 5513/5516, ANNEALED, BALL BURNISHED AND PASSIVATED, PER QQ-P-35, TYPE VI OR VII.			
TI	TITANIUM PER AMS-4901			

CUSHION IDENTIFICATION CODES		CUSHION COLOR IDENTIFICATION	AVAILABLE CUSHION PROFILES
()	CHLOROPRENE, PER AMS 3209 AND LAC 422544, TEST 2.	BLACK	
AF	NITRILE, AROMATIC FUEL RESISTANT, PER AMS 3215.	BLACK W/RED STRIPE	
BB	CHLOROPRENE PER AMS 3209 AND OZONE RESISTANT TESTED PER MIL-C-8603, PARA. 4.5.3 AND LAC 422544, TEST 2.	BLACK W/BLUE IDENTIFIER EXTENDING LENGTHWISE BOTH SIDES	
BW	SILICONE RUBBER PER BMS 1-63 and QPL.	WHITE	
DS	SILICONE RUBBER PER DMS 2221.	OFF WHITE	
DSB	SILICONE, MOLDED SAWTOOTH, FULL BOX, PER DMS-2176, CLASS 1, GRADE 40.	RUST	
DSFN	FLUROSILICONE, MOLDED, FULL BOX, SAWTOOTH, PER DMS 2171, TYPE 1.	BLACK	
EP	ETHYLENE PROPYLENE PER DMS-1849, 50 DUROMETER CLASS 2, TYPE I.	BLACK	
EPDM	ETHYLENE PROPYLENE PER SAE J 200-2BA715B13/ANSI/ASTM-D-2000.	BLACK	 
ET	ETHYLENE PROPYLENE RUBBER PER MIL-C-85052/2.	PURPLE	
FG	FIBERGLASS WRAP, ALUMINUM BASE, PROTECTIVE COATING.	GREY	
FN	FLUROSILICONE PER MIL-R-25988, CLASS 1, TYPE 2, GRADE 60.	RED	
FNB	FLUROSILICONE PER MIL-R-25988, CLASS 1, TYPE 2, GRADE 60.	BLUE	
FS	SILICONE, MOLDED, FIBERGLASS FABRIC REINFORCED.	RUST	
FH	SILICONE, FIBERGLASS REINFORCED, PER MIL-R-3065, TA612, A6-B3-F3-GK2M AND MIL-C-9094 TYPE 2, CLASS 3.	RUST	

CUSHION IDENTIFICATION CODES		CUSHION COLOR IDENTIFICATION	AVAILABLE PROFILES
GF	SILICONE, PER ZZ-R-765B, CLASS 3B, GRADE 60, POST CURED 8 HOURS @ 400° F., FIBERGLASS LAMINATE MATERIAL SHALL BE TOTALLY FREE OF FLASH.	RUST	
GS	SILICONE RUBBER, PER LAC-C-23-1195.	GREEN	
GT	PTFE, PER AMS-3652 AND ASTM-D-3308-91a, TYPE I, GRADE I.	GREEN	
HR	SILICONE RUBBER, PER AMS 3303, MIL-C-8603.	RUST	
HW	SILICONE RUBBER, PER AMS 3303, MIL-C-8603.	WHITE	
HY	SILICONE RUBBER, PER AMS 3346, 150 LB TEAR.	RUST	
NB	NITRILE BUTADIENE, RUBBER PER MIL-C-85052/1.	YELLOW W/BLACK IDENTIFIER	
NS	SILICONE RUBBER, MODIFIED AMS 3303, NON OUTGASSING.	RUST	
NT	CHLOROPRENE, PER AMS 3209 AND LAC 422544, TEST2	BLACK	
PB	PTFE IMPREGNATED PBI- POLYAMIDE GLASS BLEND FABRIC, PER BPS-C-155. TEMPERATURE: 550° F.	BROWN	
PP	ETHYLENE PROPYLENE, PER DMS-1849 TYPE 2, CLASS 1, GRADE 70.	PURPLE	
R	SILICONE RUBBER, PER AMS 3347, HIGH TEAR STRENGTH.	RED	
RG	SILICONE RUBBER, PER BPS-C-163, HIGH TEAR STRENGTH (190 LBS), SKYDROL RESISTANT , MARKED WITH MFRS COMPOUND # AND CURE DATE.	GREY	
RGB	SILICONE RUBBER, PER BPS-C-163, FULL BOX, HIGH TEAR STRENGTH (190 LBS), SKYDROL RESISTANT .	GREY	
RP	SILICONE RUBBER, HIGH TEAR(190 LBS), SKYDROL RESISTANT, PER REEVES COMPOUND 13047 POST CURED 16 HOURS @ 450° F.	GREY	
SN	PER SAE J200-2BA715B13.	BLACK	
SF	SILICONE RUBBER, FABRIC REINFORCED, PER MIL-C-85052/3.	LIGHT BLUE	
STFN	FLUOROSILICONE, MOLDED W/CHANNEL, PER DMS-2171, TYPE I, CLASS 1, GRADE 60.	BLACK	
STYN	NITRILE BUTADIENE RUBBER, MOLDED SAWTOOTH, PER MIL-C-85052/1.	YELLOW	
T	PTFE, PER AMS-3652 AND ASTM-D-3308-91a, TYPE I, GRADE I.	WHITE	
TN	EPDM, PER SAE J200-2BA715B13.	BLACK	
WC	SILICONE, MOLDED SAWTOOTH, PER DMS-2176, CLASS 1, GRADE 40.	RUST	
X	PTFE, PER AMS-3652 AND ASTM-D-3308-91a, TYPE I, GRADE I. NON SLIP TREATED.	BROWN	
YN	NITRILE BUTADIENE RUBBER, MADE FROM MIL-C-85052/1 COMPOUND AND CERTIFIED TO AMS 3215. OZONE RESISTANCE PER MIL-C-8603 PARAGRAPH 4.5.3.	YELLOW	

HOW TO ORDER

The following information is classified by basic J&M Part Number. The addition of certain suffixes will complete the clamp to the desired configuration.

- 1) Select the desired clamp configuration that best suits your application from the catalog.
- 2) Specify mounting hole and desired width of clamp from catalog page or from (fig. 1).
- 3) Specify "W" when wedge is required, omit if wedge is not required, when ordering cushioned clamps.
- 4) Add metal designation from metal identification table. (Note, standard plating applies unless otherwise specified.)
- 5) Specify required diameter of clamp in 1/16" increments. (For example 1/2"=8). (see fig. 2.)
 - a) When specifying multiple tubes, include the number of tubes and express tube diameter in 1/16" increments. (see fig. 3)
 - b) When specifying rectangular clamp configuration, "A" and "B" dimensions are expressed in 1/16" increments. (see fig. 4)
- 6) When specifying saddle if a bottom bar is required for the application add the letter "B" after metal identification code. (see fig. 5)
- 7) Select cushion material required by the environment of the application from the cushion identification chart.

Metal Width	Hole Size										
	.128	.147	.173	.204	.281	.343	.406	.468	.531	.593	.656
1/4"	12	22	32								
3/8"	13	23	33	43							
1/2"	14	24	34	44	54						
5/8"				45	55	65	75				
3/4"				46	56	66	76	86	96		
1"					58	68	78	88	98	108	118
1 1/4"					510	610	710	810	910	1010	1110

(fig.1)

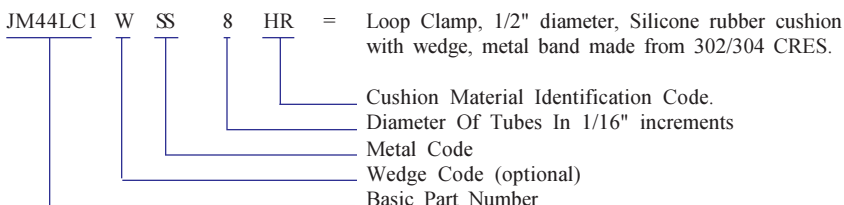

(fig.2)

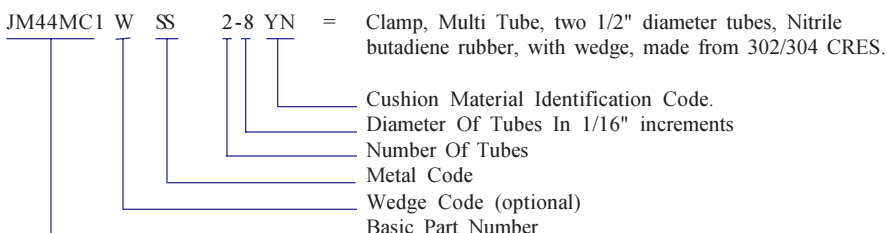

(fig.3)

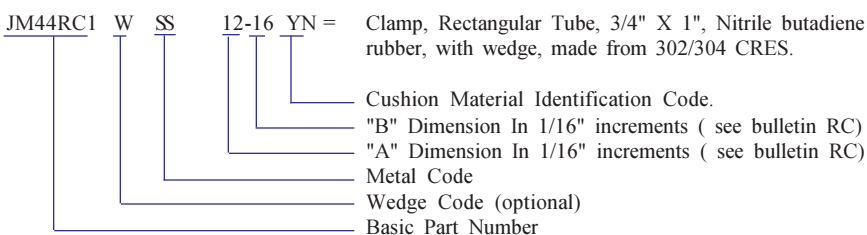

(fig.4)

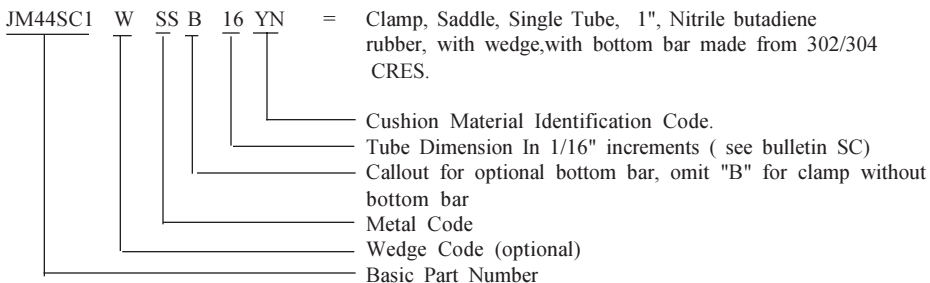

(fig.5)